



4600 Series

Gasketed & Welded Diaphragm Valves

Introduction

Available in gasketed and welded versions, this valve offers a Cv of 0.2. Operating temperature range of the welded construction version is -65° to +600° F (-54° to +316° C), permitting it to be used for high temperature bake-out. The gasketed version can be used in high vacuums, corrosive fluids, and gas analysis.



Typical Applications

- High temperature bake-out
- High vacuum
- Instrumentation
- Research labs
- Gas analysis
- Corrosive fluids

Features & Benefits

- Monel® construction
- Diaphragm provides low internal volume and low dead space
- ¼" socket weld tube extensions
- All welded models may be used for bake-out temperatures to 600° F (316° C) – plastic handle cap must be removed
- Select from globe or angle flow patterns
- Compact size
- All models can be base mounted

Gasketed Valves

- Square drive on handle permits reach rod operation for remote areas
- Easy replacement of diaphragm assembly
- Special High Tolerance NPT Thread

Technical Data

	GASKETED	WELDED
MAXIMUM OPERATING PRESSURE	300 psig @ 70° F (2.07 MPa @ 21° C)	vacuum to 300 psig @ 70° F
VACUUM	10 ⁻⁵ Torr	—
TEMPERATURE RANGE	-65° F to +240° F (-54° C to +116° C)	-65° F to +600° F (-54° C to +316° C)
ORIFICE SIZE	0.125 (3.2 mm)	0.125 (3.2 mm)
Cv FACTOR	0.2	0.2
INTERNAL VOLUME	0.11 cubic inches	0.11 cubic inches
HELIUM LEAK TEST - ENVELOPE MAX.	5 x 10 ⁻⁹ SCC/SEC	—
- SEAT MAX.	1 x 10 ⁻⁸ SCC/SEC	—

HOKE Incorporated

405 Centura Court • PO Box 4866 (29305) • Spartanburg, SC 29303
 Phone (864) 574-7966 Fax (864) 587-5608
 www.hoke.com • sales@hoke.com

packless valves

4600 Series

Materials of Construction

Gasketed

	DESCRIPTION	MONEL®
1	Body	Monel®
2	Tube extensions	Monel®
3	Diaphragm	Inconel®
4	Stem point	Monel® K-500
5	Stem	316 stainless steel
6	Compression spring	Music wire
7	Housing	Brass, nickle-plated
8	Handle	Ni silver
9	Gasket	Aluminum

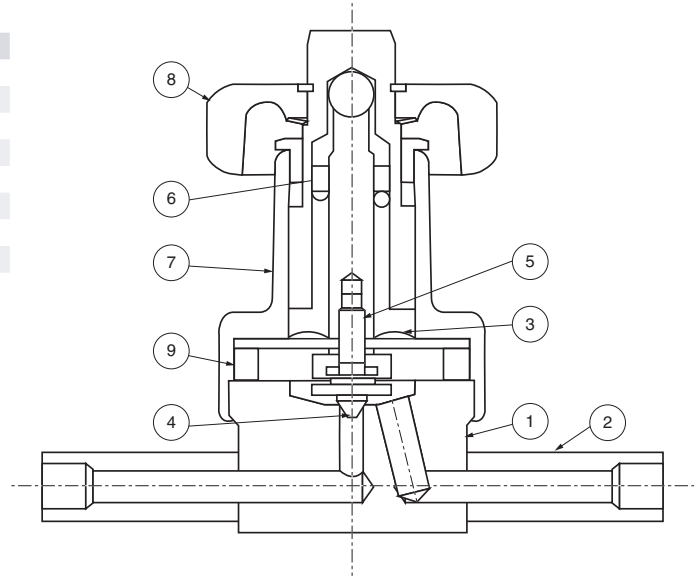

Materials of Construction

Welded

	DESCRIPTION	MONEL®
1	Body	Monel®
2	Diaphragm	Inconel®
3	Stem point	Monel® K-500
4	Diaphragm ring	Monel®
5	Diaphragm clamp	316 stainless steel
6	Stem	316 stainless steel
7	Compression spring	Music wire
8	Housing	316 stainless steel
9	Handle	Ni silver

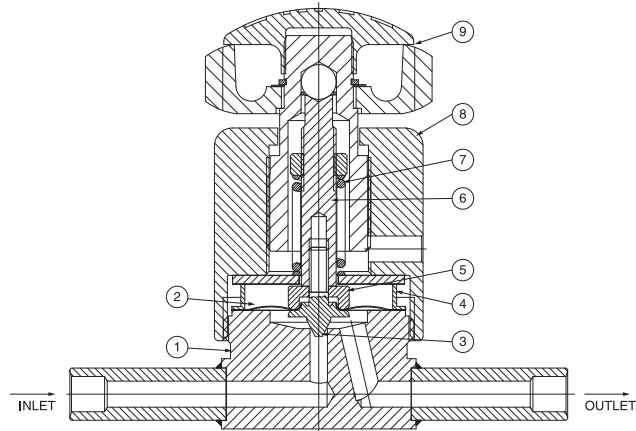

This tube union is designed for use with all 4600 Series valves in high vacuum applications. The gland end may be connected to tubing or block with 1/4" O. D. The seat end will fit tubing or a projection of 3/8" O. D. (To order, specify part number 62076.)

DESCRIPTION	MATERIAL
Seat end	Monel®
Gland	Monel®
Male Nut	aluminum bronze

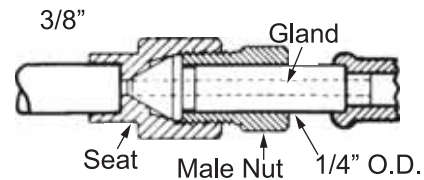

4600 Series

Dimensions

Gasketed

PART NUMBER		D	E	F	H	BASE MOUNTING
4613N4M	inch	2 5/8	3 1/2	1 5/8	1/4	2 holes on 1" dia. 1/4-20 NC Thd. Full thd. 3/8" deep
	mm	66	89	41	6	
4623N4M	inch	2 5/8	1 3/4	1 5/8	1/4	
	mm	66	44	41	6	

Dimensions for reference only, subject to change.

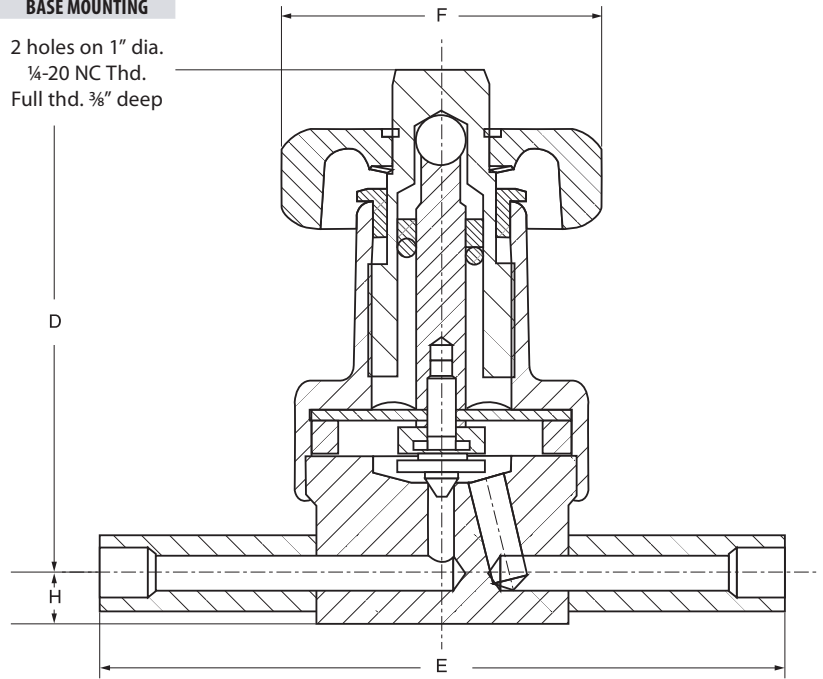

Straight flow pattern

Dimensions

Welded

CONNECTIONS	FLOW PATTERN		D	E	F	H	BASE MOUNTING
1/4" O.D. tube	Angle	inch	2 13/16	1 3/4	1 5/8	1/4	2 holes on 1" dia. 1/4-20 NC Thd. Full thd. 3/8" deep
		mm	71	44	41	6	
1/4" O.D. tube	Straight	inch	2 13/16	3 1/2	1 5/8	1/4	
		mm	71	89	41	6	

Dimensions for reference only, subject to change.

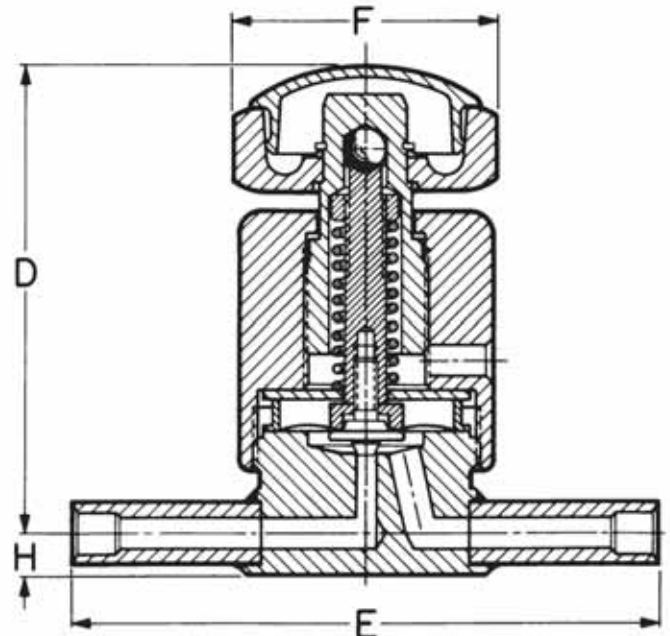

Straight flow pattern

4600 Series

How to Order

Order valve by part number shown in chart.

	CONNECTIONS	FLOW PATTERN	ORDER BY PART NUMBER
			MONEL®
GASKETED	¼" Tube extensions	Straight	4613N4M
	¼" Tube extensions	Angle	4623N4M
WELDED	¼" Socket weld tube extensions	Straight	4618N4M
	¼" Socket weld tube extensions	Angle	4628N4M

For Your Safety

It is solely the responsibility of the system designer and user to select products suitable for their specific application requirements and to ensure proper installation, operation, and maintenance of these products. Material compatibility, product ratings and application details should be considered in the selection. Improper selection or use of products described herein can cause personal injury or property damage.

Garlock® is a registered trademark of Coltec North Carolina Inc.

Gyrolok® is a registered trademark of HOKE Incorporated

Monel® and Inconel® are registered trademarks of Special Metals Corporation

Teflon® and Fairprene® are registered trademarks of DuPont

www.goodrich.com

www.hoke.com

www.specialmetals.com

www.dupont-dow.com