

GO REGULATOR, INC.

A division of CIRCOR International, Inc.



PR-7 Series Ultra High Flow Adjustable Pressure Reducing Regulator

The PR-7 Series has been designed for those applications using high gas flow rates while still requiring a compact package. In addition, this unit will handle hydrogen flows up to 1000 liters per minute with none of the resonance problems typical with many regulators attempting such an application.

While designed for gas flow applications with low inlet pressures and low differential pressures, this valve has been constructed to withstand inlet pressures up to 3600 psig. With capability of holding outlet pressures closely with large changes of flow requirements, this valve is very suitable as a primary pressure supply to other pressure regulators located downstream.

Features & Specifications

- Minimal droop with large flow increased
- No resonance with large hydrogen flows
- Stainless steel diaphragm
- Stainless steel (316L) or brass construction (optional Hastelloy, Monel, or chrome-plated brass)
- T-handle adjusting assembly for easier adjustment in the 250 and 500 psig ranges
- Material of construction: brass, stainless steel, Viton®, Teflon®, PEEK, or Kalrez®
- Stainless steel cap
- C_v flow coefficient = 1.1 (full C_v with 1/2" ported unit only)
- Operating temperatures up to +250° F (+121° C)
- Maximum inlet pressure of 3600 psig with PEEK seat
- Inlet/outlet connections: 1/4", 3/8", or 1/2" FNPT
- Outlet pressure ranges of: 0–10, 0–25, 0–50, 0–100, 0–250 & 0–500 psig

Options

- Self relieving
- Panel mount
- Captured vent

2301 Wardlow Circle
Corona, CA 92880
tel 909.270.6200
fax 909.270.6201
www.goreg.com
sales@goreg.com

PR-7 Series

Ultra High Flow Adjustable Pressure Reducing Regulator

How to Order

See page 3 for standard configurations. For additional configurations, consult the factory.
See page 4 for port locations.

Maximum Temperature & Operating Inlet Pressures

Up to 100 psig Outlet Pressure			
Seat Material	Maximum Temperature*	@	Maximum Operating Inlet Pressure
Teflon®	150° F (66° C)	@	1000 psig (6.90 MPa)
PEEK	250° F (121° C)	@	3600 psig (24.82 MPa)
Viton®	250° F (121° C)	@	300 psig (2.07 MPa)
Kalrez®	250° F (121° C)	@	300 psig (2.07 MPa)

* Temperatures in excess of 175° F (80° C) require the use of a metal knob or the tamper proof option.

0–250 & 0–500 psig Outlet Pressures (T Handle or Tamper Proof)			
Seat Material	Maximum Temperature	@	Maximum Operating Inlet Pressure
Teflon®	150° F (66° C)	@	1000 psig (6.90 MPa)
PEEK	250° F (121° C)	@	3600 psig (24.82 MPa)

Teflon®, Viton® and Kalrez® are registered trademarks of Dupont Corporation.

Outline and Mounting Dimensions

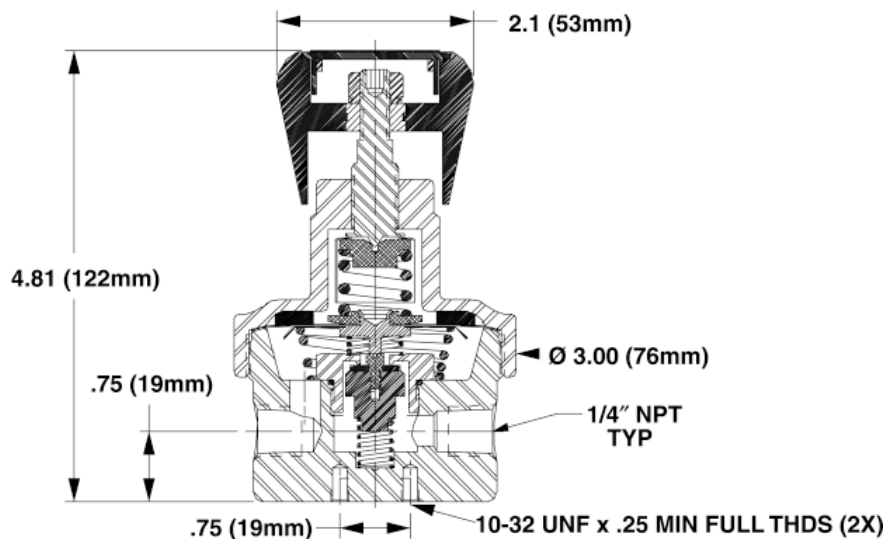

Weight - 3.2 lbs (1.45 kg)

PR-7 Series - Pressure Reducing Regulator

Material of Body	
1	SS 316L
2	Brass
4	Monel
6	Hastelloy C
8	Brass Chrome Plated
Port Configuration (see page 4) STANDARD BODY "A" (ONE INLET PORT AND ONE OUTLET PORT)	
A	
Process port types (gauge port type, if specified)	
1	1/4" FNPT (1/4" FNPT Gauge Ports)
4	3/8" FNPT (1/4" FNPT Gauge Ports)
5	1/2" FNPT (1/4" FNPT Gauge Ports)
J	1/2" Triclover (1/4" FNPT Gauge Ports)
L	3/4" Triclover (1/4" FNPT Gauge Ports)
Surface Finish of Diaphragm Cavity	
1	<25 Ra
Seat Material	
D	Viton
I	Teflon
K	Kalrez
Q	PEEK
Flow Coefficient (Cv)	
8	1.1
Output Range	
C	0 - 10 Psig
D	0 - 25 Psig
E	0 - 50 Psig
G	0 - 100 Psig
I	0 - 250 Psig
J	0 - 500 Psig
S	0 - 1 Psig
R	0 - 150 Psig
Diaphragm Type	
1	Non Self Relieving
3	Self Relieving
Diaphragm Material	
Dia Matl	
1	Teflon / SS
2	Teflon / Viton
5	Viton / SS
6	Tefzel Ring / SS
7	Tefzel Ring / Hastelloy C
8	Teflon / Inconel
0	Teflon / Hastelloy C
Cap Assembly	
1	Standard, S.S.
2	T-Handle, S.S.
3	T-Handle, Panel Mount, S.S.
4	Panel Mount, S.S.
5	Captured Vent, Aluminum
6	Captured Vent, Panel Mount, Aluminum
7	Captured Vent, S.S.
8	Tamper Proof, S.S.
9	Fine Adjust, 1/2" Panel Mount, S.S.
0	Fine Adjust, 1 3/8" Panel Mount, S.S.
C	Captured Vent, Panel Mount, S.S.
E	Tamper Proof, Panel Mount, S.S.
H	1/4" NPT Dome Loaded, S.S.

PR 7 -

Material	Port Config.	Port Style	Cavity Finish	Seat Material	Flow (Cv)	Output Range	Diaphragm Type	Diaphragm Material	Cap Assembly	

PORT LOCATIONS (SINGLE STAGE PRESSURE REGULATOR)

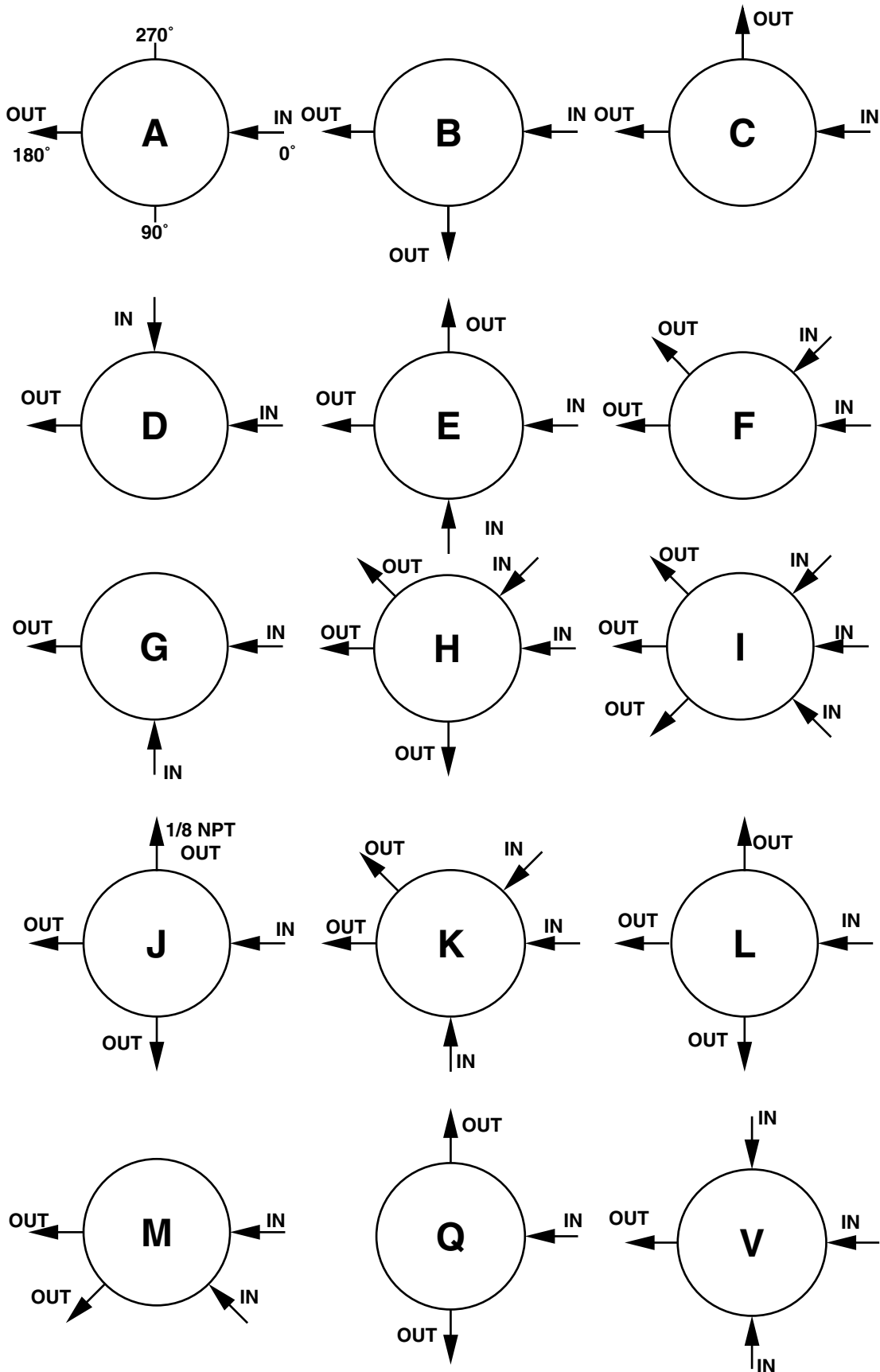

LOCATION OF PORTS FROM TOP VIEW